

# FREQUENCY CALIBRATION USING WWV

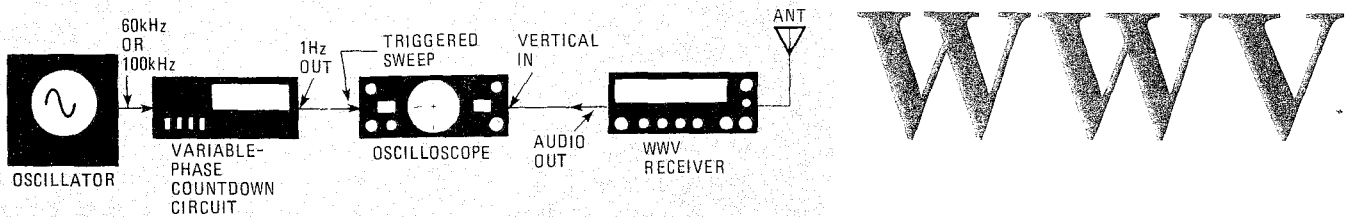

FIG. 1—BLOCK DIAGRAM OF TEST SETUP used to determine the drift of the local clock.

R.W. BURHANS

*WWV is a source of highly accurate time- and frequency-signals. Here's a method that lets you use those signals to calibrate your own frequency standards.*

AS ELECTRONIC CIRCUITS GET MORE complex, the level of accuracy needed to test those circuits also increases. While accurate measurement of voltage, current, and resistance present their own problems, often it's even harder to perform accurate frequency measurements. That's because they can only be as accurate as the crystal timebase in your frequency counter.

Getting a high degree of accuracy when calibrating a crystal timebase has been almost impossible without expensive calibration equipment. That's especially true if you want the calibration to be traceable to the NBS (National Bureau of Standards). The only inexpensive alternative is to calibrate the timebase using the time signals transmitted by radio stations WWV and WWVH. Those stations are operated by the National Bureau of Standards and they transmit highly-accurate cesium-clock derived time signals on 2.5-, 5-, 10-, 15-, and 20-MHz. (A complete guide to the WWV and WWVH broadcast services can be found in NBS Special Publication 432, *NBS Frequency and Time Dissemination Services*. The document is available for 60 cents from the Superintendent of Documents, U.S.

Printing Office, Washington, DC 20402.) The commonly accepted method for calibrating an oscillator using WWV transmissions is to zero-beat the oscillator against the WWV carrier frequency.

However, a small controversy has developed as to whether or not crystal oscillators such as those found in frequency counters can be accurately calibrated using that method. (See "Equipment Reports," *Sabtronics 8610A*, **Radio-Electronics**, February 1982, and John H. Hennings rebuttal letter, **Radio-Electronics**, June 1982). The controversy arises from the fact that the ionosphere is unstable (its condition fluctuates cyclicly over a 24-hour period), and affects the propagation of the WWV transmissions. The unstable nature of the ionosphere limits the accuracy of the WWV transmissions to 0.1 part-per-million (1 Hz in 10 MHz). However, by applying a technique used long before the days of atomic clocks, it is possible to obtain an accuracy of 0.001 part-per-million (1 Hz in 10 GHz) using WWV transmissions, provided that the oscillator you're calibrating is kept operating continuously for long periods of time.

### The calibration technique

Rather than calibrate the oscillator against the WWV carrier frequency, the technique outlined here uses the audible ticks that are transmitted by WWV and WWVH to identify the seconds. Each tick transmitted by those services consists of a 1000-Hz, 5-ms tone. The actual tick, therefore is composed of five cycles of a 1000-Hz sinewave.

The technique is illustrated in the block diagram in Fig. 1. The received time tick from WWV is displayed on the vertical axis of an oscilloscope. The output of the crystal oscillator is connected to a variable-phase countdown circuit that divides the oscillator frequency down to one pulse per second. Thumbwheel switches in the countdown circuit vary the phase of that 1-pulse-per-second waveform, which is used to trigger the oscilloscope. The sweep rate is set to 1-ms-per-division and the thumbwheel switches on the countdown circuit are adjusted until a sinewave appears. Since the 1000-Hz tone from WWV occurs only once each second and lasts for only 5 ms, the thumbwheel switches may have to be adjusted almost through their entire range before

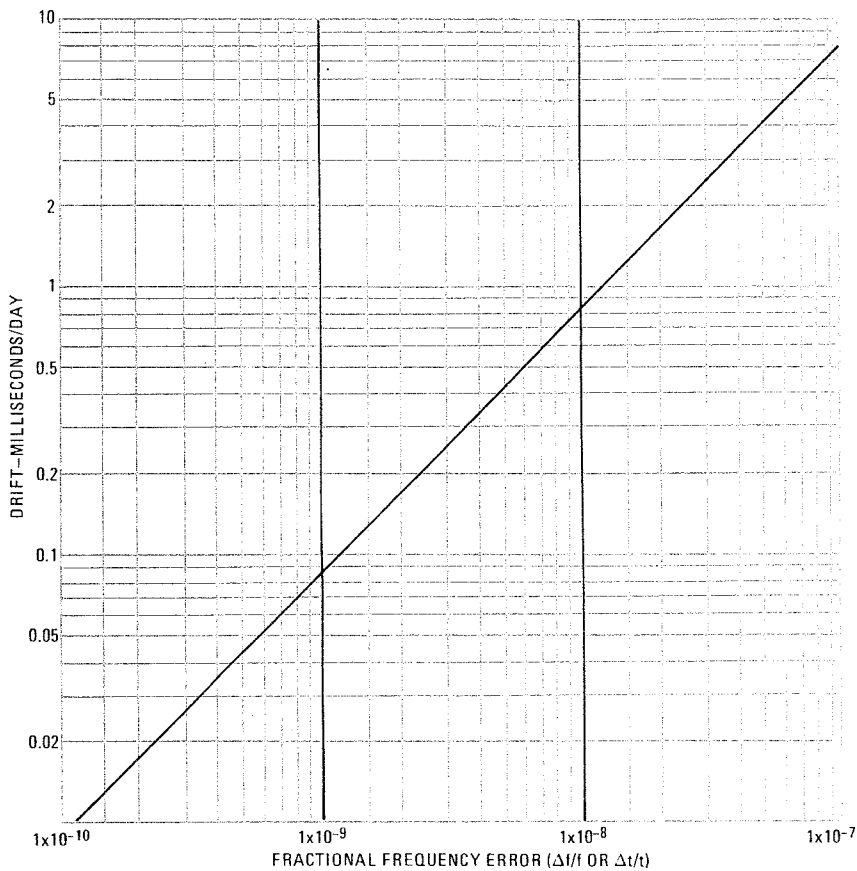

FIG. 2—THE FRACTIONAL FREQUENCY ERROR of the local clock can be determined from this graph once the drift is known.

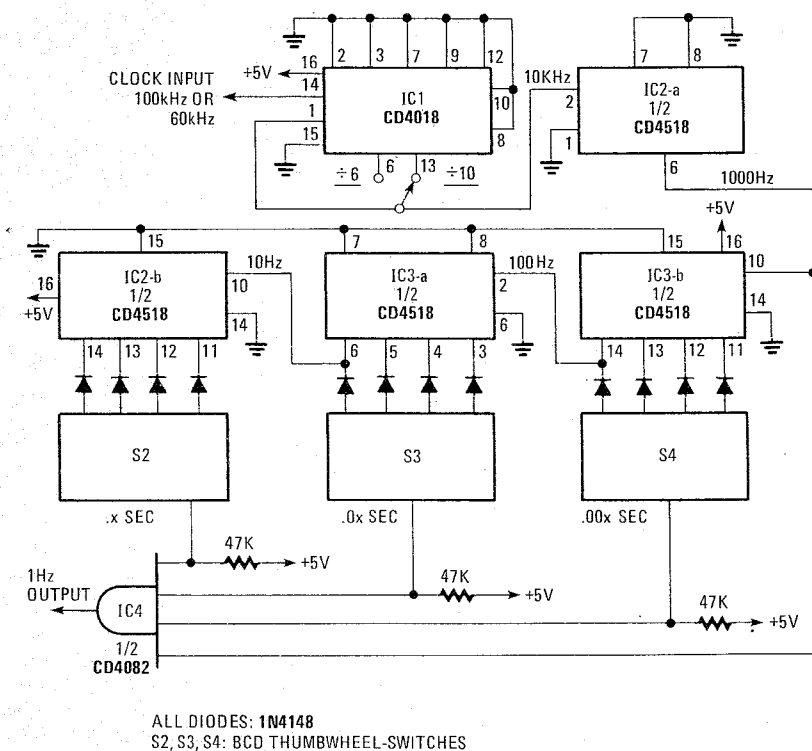

FIG. 3—VARIABLE PHASE COUNTDOWN CIRCUIT. The thumbwheels are adjusted until the sinewave is aligned with the beginning of the tick trace.

the sinewave can be seen. Remember, it lasts for only  $\frac{1}{200}$  second.

After the sinewave does appear, the thumbwheel switches are again adjusted until the leading edge of the first cycle of the sinewave aligns with the start of the oscilloscope trace. The drift of that trace determines the frequency error of the crystal oscillator. If the sinewave drifts one full cycle in about a minute, then the crystal oscillator is set to within only  $\pm 10$  parts-per-million. If the sinewave drifts one cycle in 15 minutes then the frequency stability is about 1 part-per-million. The rate of change of that drift is called the aging rate of the crystal.

To obtain higher accuracies, it is necessary to measure the drift over several days. The ionosphere will indeed affect the accuracy of the results, but its effect will be minimized if the measurements are always made at the same time of day. The change in the settings of the thumbwheel switches required to align the sinewave with the beginning of the trace is recorded every day at the same time each day. The drift can be estimated to within perhaps 0.1 millisecond by observing where the leading edge of the first cycle of the sinewave is with respect to the starting point of the trace. The drift (in milliseconds) over a 24-hour period of time can be used to determine the fractional frequency error of the clock by using the graph shown in Fig. 2. Although that may be a lot more trouble than the average observer is willing to take to determine his clock error, the point is that if accuracy is necessary, it can be obtained using WWV time signals.

The aging rate of a crystal itself changes with time, so it is necessary to reset the fine trim on the local clock-oscillator about once a month to maintain accuracy. An additional problem with temperature-compensated and oven-controlled crystal oscillators is that when they are shut off and then turned back on again, the aging rate starts at a new point. However, that problem is eliminated if the oscillator is kept running continuously, as in the frequency counters now sold that have standby operation, in those, an oven-stabilized crystal oscillator is always on.

### The countdown circuit

The variable-phase countdown circuit is shown in Fig. 3. This circuit is intended to be driven from a 100-kHz or 60-kHz source, but it can easily be driven from a 1-MHz or 10-MHz source with the addition of a couple of decade dividers using Schottky TTL or even some CMOS IC's. The thumbwheels can be adjusted to provide any phase of a 1-second tick from 0 to 999 milliseconds in one-millisecond increments.

R-E