

Down-Under Depth Sounder

Get your feet wet with this Australian construction project. We promise that you won't get in over your head.

Reprinted with permission from the November, 1982, issue of *Electronics Australia*, PO Box 163, Chippendale, 2008, NSW Australia.

Depth sounders on pleasure craft are primarily used for simply measuring water depth, although some more elaborate (and expensive) models can locate fish

or even produce a scan of the sea bottom so that reefs and other sunken objects can be located. The unit described here falls into the former category and, as

such, is designed to be easy to construct and to operate.

After all, what could be easier than reading a few numbers off a digital display?

The circuit was developed by Sydney engineer Neville Harleck whose company, Monitor Instruments, can supply complete kits for the project. We at *Electronics Australia* simply assembled the unit depicted here and prepared the constructional details.

Once assembled, the kit certainly looks the part. Two printed circuit boards—a display board and a main board—accommodate virtually all the electronics, and these are housed in a white molded plastic case. Overall case dimensions are a compact 125 mm W × 140 mm D × 58 mm H.

While the case is not watertight, it is reasonably weatherproof and should stand up well to the rigors of the marine environment. Its compact size also means that you should have no difficulty in finding a suitable mounting position for the device regardless of the type of boat you own.



Photo A. The digital depth sounder.

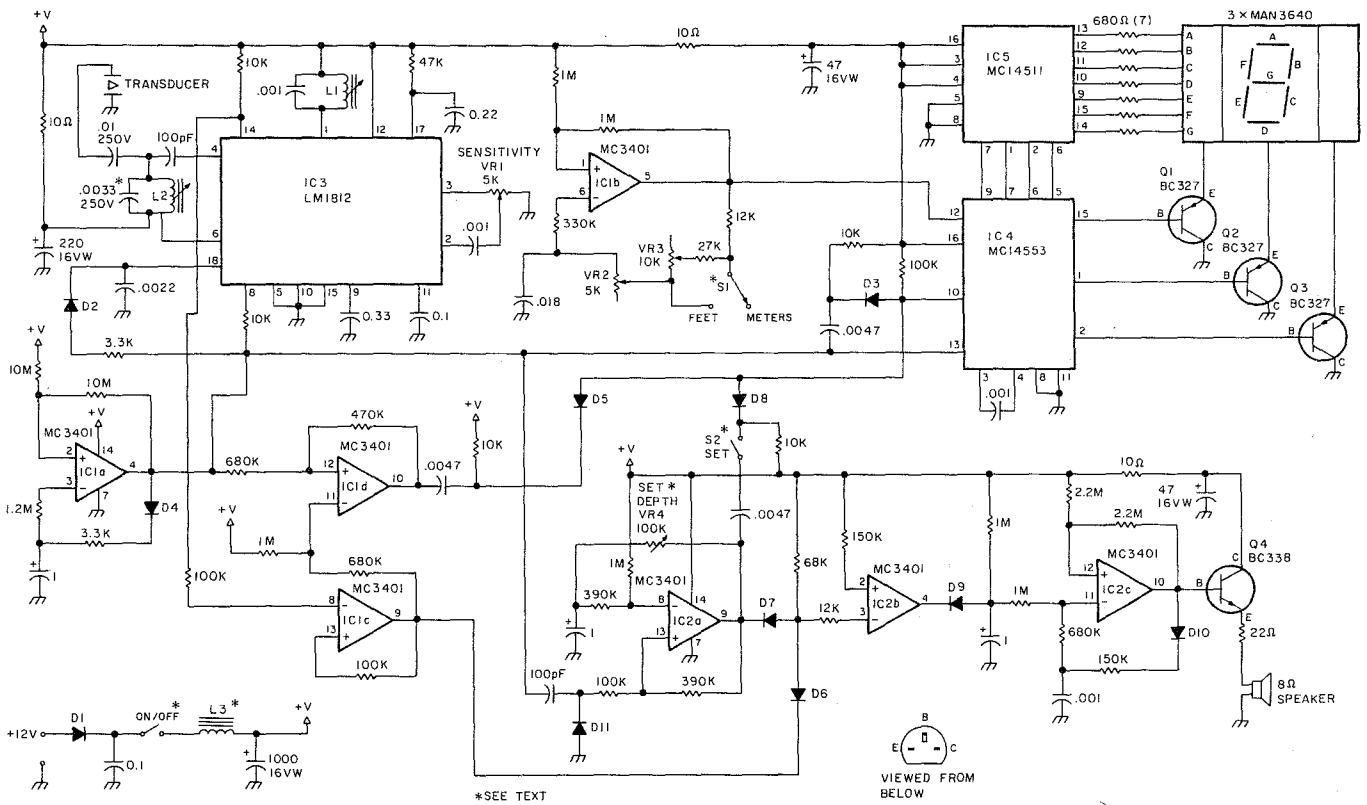

Circuit diagram for the digital depth sounder.

Other features include a bright 3-digit LED display, a sensitivity control, an alarm-depth-set control, and a feet/meters switch mounted on the rear panel. A U-shaped mounting bracket allows the case to be tilted to provide a convenient viewing angle.

The audible alarm function is a particularly useful feature. When selected, it sounds whenever the water depth decreases below a preset level, thus eliminating the need for continuous visual monitoring. The danger of running aground is never greater than when the fish are biting, or you are otherwise preoccupied!

Basic Principle

The principle on which a depth sounder operates is quite straightforward. An ultrasonic sound pulse is directed into the water and the time taken for the signal to be reflected from the bottom is measured. Since the speed of sound in water is reasonably constant, the distance the sound pulse has traveled, and hence the

water depth, can be easily calculated. Fig. 1 shows the essential elements of a depth-sounder system.

First, the transmitter generates a short pulse of 200-kHz energy and, at the same time, starts the clock. The receiver subsequently detects the reflected signal and produces a pulse that stops the clock. If the clock is counting at the correct rate, then the display will indicate the water depth directly in the appropriate units (meters or feet).

Most of the important functions of the transmitter and receiver circuits are incorporated into a single IC

made by National Semiconductor. This IC, designated the LM1812, has been around for some years now and greatly simplifies the design task for a practical depth sounder. Fig. 2 shows the block diagram of the complete unit and should be studied in conjunction with the circuit diagram in order to understand how the instrument operates.

Circuit Description

Our circuit description starts with IC1a, which functions as the timebase clock. This generates a 1-ms pulse approximately every 800 ms. This pulse activates the transmitter and resets the display and alarm functions.

IC1a, part of an MC3401 quad op amp, is wired as an astable multivibrator which

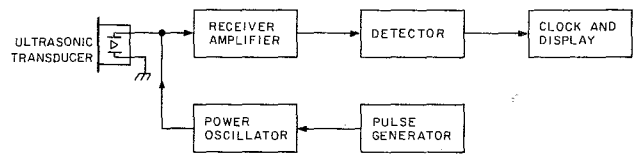

Fig. 1. Basic scheme for an ultrasonic depth-sounder circuit.

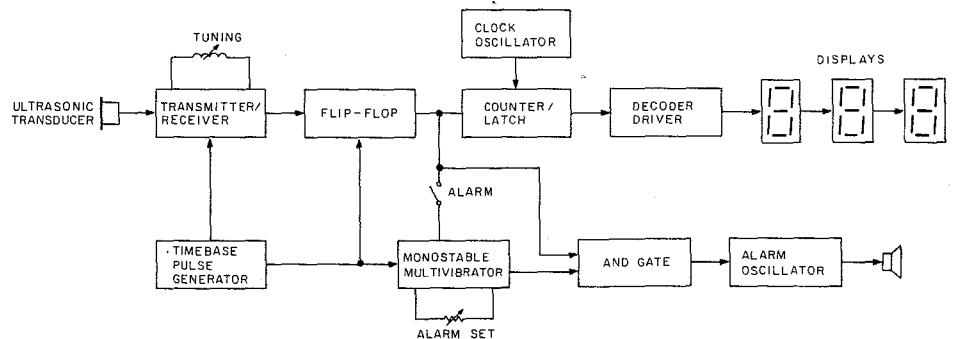

Fig. 2. Block diagram of the complete depth-sounder circuit. The transmitter/receiver is based on a single IC.

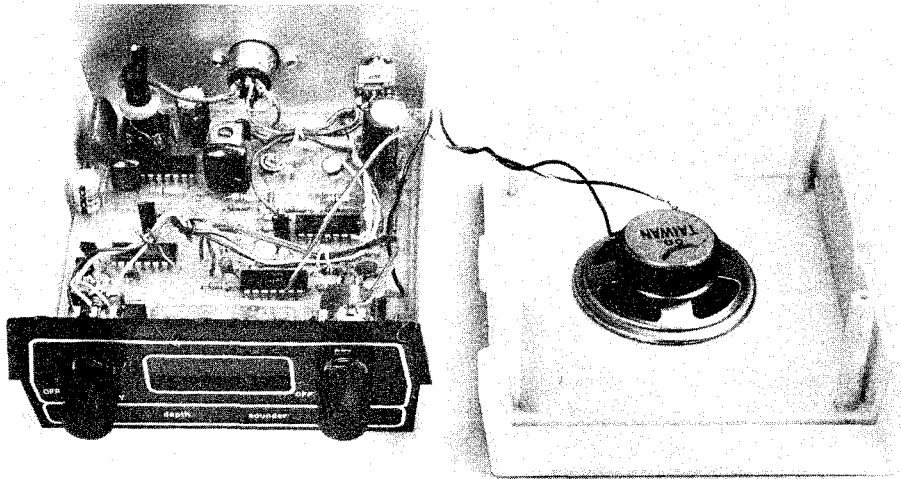

Photo B. Virtually all the circuitry is accommodated on two PC boards.

functions as follows: At switch-on, both the non-inverting input (pin 2) and the output (pin 4) are high. The 1- μF timing capacitor now charges via diode D4 and its series 3.3k- Ω resistor. When the voltage across the capacitor (and hence on pin 3 of IC1a) reaches a critical level, the output of IC1a goes low.

Since diode D4 is now reverse biased, the timing capacitor discharges via the

1.2-megohm resistor into pin 3 of IC1a. When the voltage on pin 3 goes low enough, pin 4 switches high again and the whole cycle is repeated. The 10-megohm resistor between pins 2 and 4 provides positive feedback to speed up the switching transitions.

The output of IC1a thus consists of a train of short positive-going pulses. These pulses are coupled to ultra-

sonic transceiver IC3, counter IC4, and to the non-inverting input of IC2a which controls the alarm function.

IC3 is the LM1812 transceiver chip referred to earlier. Both the transmitter and receiver sections share a common tuned circuit, consisting of L1 and the .001- μF capacitor, which makes for easy tuning. Readers are referred to the *National Semiconductor Linear Databook*

for a detailed description of this IC, as only a general description of its operation will be given here.

The timebase pulse from IC1a is applied to pin 8 of IC3 via a 10k- Ω resistor. This causes the transmitter to "fire" at a frequency determined by the tuned circuit, the output signal appearing at pin 6. This is coupled to the transducer via L2, a parallel 3300-pF capacitor, and a .01- μF blocking capacitor. The signal appearing across the transducer thus consists of a 1-ms burst of 200-kHz energy of about 150-200 V peak-to-peak. At the end of the 1-ms clock pulse, IC3 reverts to the receive mode.

Signals picked up by the transducer are coupled into the first receiver stage at pin 4 via a 100-pF capacitor. Following amplification, the signal appears at pin 3 and is coupled into the next amplifier stage via VR1, the sensitivity control. It is this stage that is tuned by the LC network on pin 1.

As far as the user is concerned, the signal is not seen again until it appears at pin 14, and by this time it has been amplified, detected, shaped, clamped, and clipped so that we get a nice clean negative-going pulse from the supply voltage to ground.

The functions of a few other pins on IC3 should also be considered before moving on to the next section. It will be noticed that the timebase pulse is also fed into pin 18 via a 3.3k- Ω resistor and series diode D2. This is done to inhibit the detector during the transmit time and thus prevent a false output signal appearing at pin 14. The 47k- Ω resistor and 0.22- μF capacitor connected to pin 17 provide a measure of impulse noise rejection.

The 0.33- μF capacitor on pin 9 is charged during the transmit period and serves to inhibit the second stage of the receiver. As the

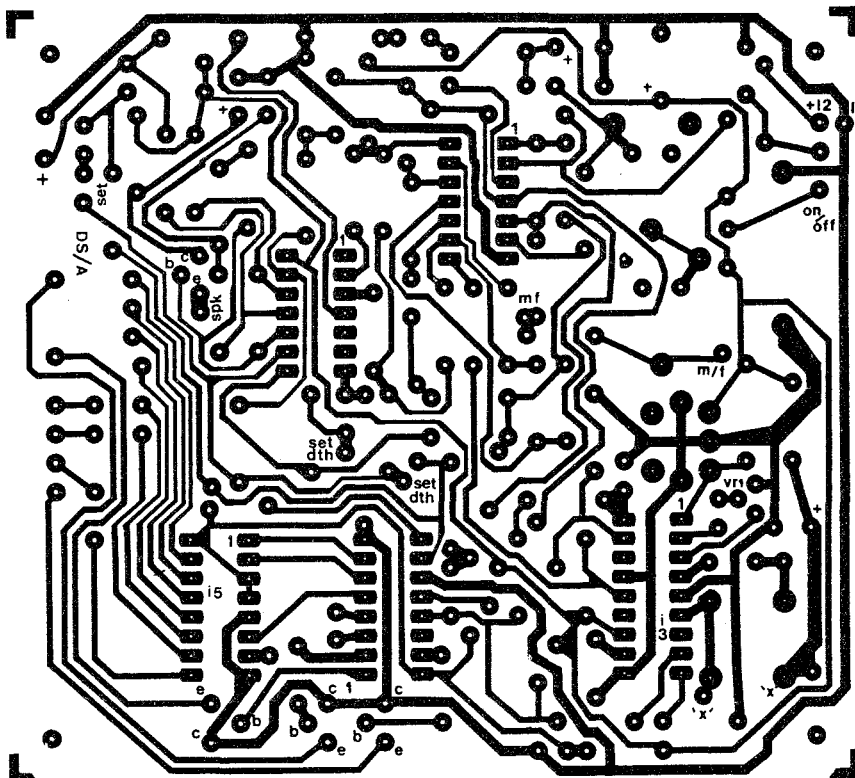

Fig. 3. PC board for the depth sounder.

quite a wide range of temperature and salinity. It will therefore take 1 second to receive an echo in 750 meters of water, since the sound pulse has to go down and up. Thus, if the clock is set to 750 pulses per second, the counter will count up to 750 and the water depth will be displayed directly in meters.

If we want the display to read in feet, then the oscillator frequency can be found simply by multiplying 750 by 3.28 (the conversion factor from meters to feet), which gives 2460 Hz. Thus, the clock must run at 2460 Hz for feet and 750 Hz for meters. A fathoms display could be achieved with a clock of $2460/6 = 410$ Hz.

Finally, we come to the alarm function. The depth at which the alarm sounds is set using front-panel alarm-set control VR4. First, the alarm-set control is pulled out to display the alarm setting. The control is then rotated until the display reads the required alarm depth and then pushed in again. The display immediately reverts to the water depth and, if this is less than the alarm setting, an audible warning is produced.

All alarm functions are controlled by IC2, an MC3401 quad op amp. IC2a functions as a monostable multivibrator, the period of which is determined by VR4 and the 1- μ F timing capacitor. The monostable is triggered by the timebase pulse which is coupled in via a 100-pF capacitor and causes pin 9 to go high, thus reverse biasing diode D7.

If an echo is received while the monostable out-

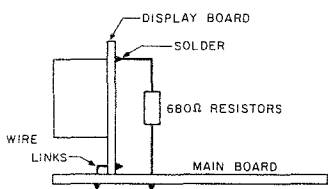

Fig. 5. Diagram showing how four of the 680-Ohm resistors are mounted.

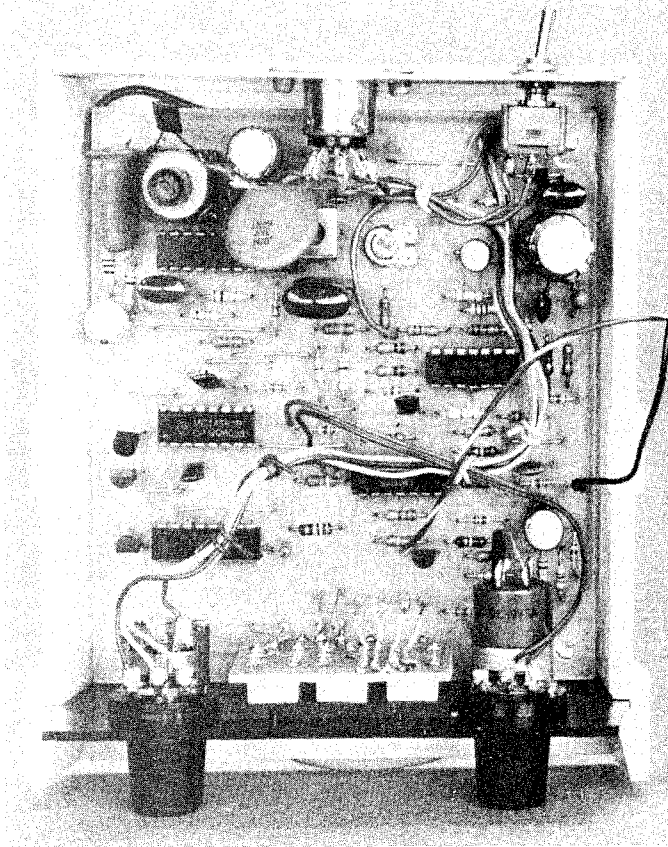

Photo C. Close-up view of the completed PCB assembly. Note that the seven 680-Ohm resistors adjacent to the display board are mounted end on.

put is high, then both D6 and D7 will be reverse biased for the duration of the echo pulse (i.e., for as long as pin 9 of IC1c remains high). This causes pin 3 of IC2b to go high and the pin 4 output to go low. Since it is now forward biased, the anode of diode D9 also goes low, enabling oscillator IC2c to start up.

IC2c is a voltage-controlled oscillator whose frequency depends on the voltage at the anode of D9, i.e., the charge on the 1- μ F capacitor. Initially, the 1- μ F capacitor is discharged and

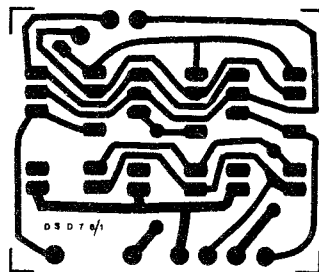

Fig. 6. PC board for the display.

the oscillator starts at a high frequency. When the echo pulse ends, D9 is reverse biased again and the 1- μ F capacitor charges towards the positive supply rail via a 1-megohm resistor. As the voltage across this capacitor rises, the discharge current from the .001- μ F capacitor slows and the output frequency drops lower and lower until eventually the oscillator stops.

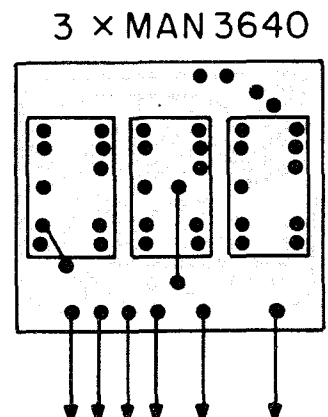

Fig. 7. Parts placement for the display PCB.

NPN transistor Q4 simply functions as a buffer and drives a small loudspeaker in its emitter circuit via a 22-Ohm resistor. The result is a siren-like note pulsed at the timebase frequency.

The alarm can sound only if an echo pulse is received while the output of monostable IC2a is high. Thus, it is the monostable pulse width that determines the alarm depth and this is displayed by using the trailing edge of the pulse to trigger the latch enable (pin 10) of counter IC4.

First, however, the echo pulse must be disabled, and this is done by setting the sensitivity control (VR1) to minimum. The output of monostable IC2a is differentiated by the .0047- μ F capacitor and the negative-going pulse produced at the trailing edge coupled via switch S2 (on the back of VR4) and diode D8 to the latch enable of IC4. Since the timebase simultaneously resets IC4 and enables IC2a, the display will now show the alarm depth in the appropriate units.

Power for the circuit is derived from a 12-V battery (normally fitted to the boat). Diode D1 provides protection against reversed supply polarity, while 0.1- μ F and 1000- μ F capacitors provide supply decoupling and filtering. Choke L3 is not supplied as part of the kit and is not fitted unless problems are encountered with ignition interference (see Construction).

Construction

Construction can begin with the assembly of the main PCB according to the overlay diagram. Insert the wire links first, followed by the resistors, capacitors, coils, diodes, and transistors. Take care to ensure that all polarized components are mounted the right way round.

The ICs should be inserted last. Note that IC4 and IC5 are CMOS devices and

should be treated accordingly. When soldering these devices, ground the barrel of your soldering iron to the ground track on the PCB (use a small clip lead) and solder the supply pins (8 and 16) last.

The display PCB should be assembled next. Watch the orientation of the displays and note that the links must go in first. The display board is mounted on the main board using six tinned copper-wire links along the bottom edge. In addition, four of the 680-Ohm current-limiting resistors are mounted between the main PCB and the display PCB and, if these are bent as shown in Fig. 3, will provide additional support.

The front-panel controls can now be mounted in position and the red perspex window cemented in place using epoxy adhesive. This done, wire the controls to the main PCB and fit the DIN socket and feet/meters switch to the rear panel.

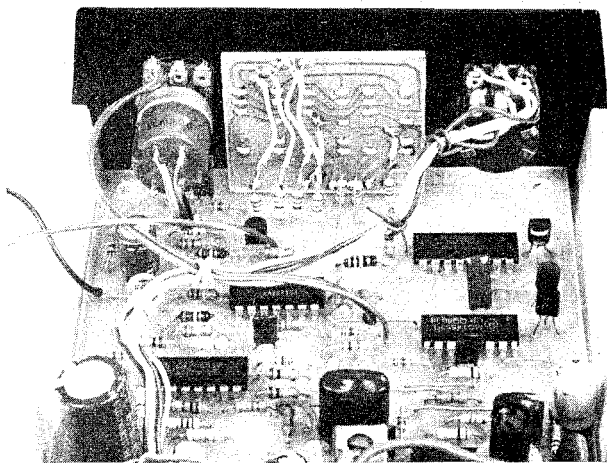

Photo D. Front panel and display PCB details. Note that the spare switch pole on the alarm-set control can be used to automatically disable the echo pulse (see text).

Complete the wiring according to the main wiring diagram and Fig. 3.

Although not part of the original design, the circuit can be easily modified so that the echo signal is automatically disabled whenever S2 is closed. As supplied, there is a spare switch pole on the back of VR4,

and this may be used to disable the echo signal by connecting it between pin 2 of IC3 and ground. With this simple modification, you won't have to fiddle with the sensitivity control each time you wish to display the alarm depth.

The loudspeaker is fitted to the top half of the case (over

the slots) by gluing it in place with contact adhesive. A piece of cloth is provided to cover the slots. Connect up the speaker, fit the transducer DIN plug with a couple of flying leads for the power connections, and you are ready for the smoke test!

Apply power (12 V) and switch on. All being well, you should be greeted by a chirp from the speaker and the display should read 000 or 001. Make sure that the alarm-set control is pushed in and fully anticlockwise (i.e., alarm off).

Now set the sensitivity control to minimum (to disable the echo pulse) and pull out the alarm-set control. Slowly rotate the alarm-set control clockwise and check that the display shows progressively higher numbers. If this check is OK, operate the feet/meters switch and check that the display changes by a 3:1 ratio. With the alarm-set control fully clockwise, the display should read a maximum of approximately 30

TRANSDUCER ASSEMBLY

Begin the transducer assembly by gluing together the two plastic pieces forming the element housing. These are molded in ABS, so use a suitable styrene adhesive. Apply adhesive sparingly to the top edges of the "fried-egg"-shaped piece and then press the two parts together, ensuring that the mounting holes are correctly aligned. Allow sufficient time for the adhesive to dry.

The barium titanate element must be prepared next. Carefully tin a small spot close to the edge of the element on each side and solder a short length of hookup wire to each spot. Be very careful with this operation, as too much heat will burn the silver off the surface of the element. Wrap the circumference of the element in plastic tape, using the tape to hold one of the wires against the edge.

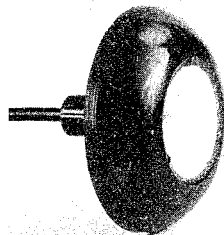
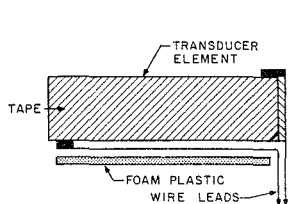

The surface where the two wires emerge is now the rear face of the transducer. Now lay the wire from the rear surface against the transducer and place the plastic foam disc in position. Use more tape to secure it in place. The two wires should now emerge from one side as shown and should be reasonably well supported by the tape. Leave about 25 mm of wire free and strip and tin 3 mm at the end of each wire.

Force one end of the coaxial cable through the hole in the stem of the housing and strip and tin the ends of the braid and the center conductor. Carefully solder the coax to the wires coming out of the transducer assembly and insulate the joints with more plastic tape.

The transducer assembly must now be pushed into the housing, carefully pulling the coax down to avoid building up a loop of cable behind the transducer.

Push the transducer down in the housing so that its front surface is about 3 mm below the lip of the housing cavity. Check the cable at the other end for shorts; if all is well, put your meter on a low ac voltage range and tap the transducer with a screwdriver handle. You should see the meter give a kick, indicating that the transducer is functioning correctly. If not, check your connections carefully.

Support the transducer assembly face up, where it can be left overnight, and you are ready for the epoxy resin encapsulation. Do not use 5-minute epoxy. You must obtain some epoxy resin with a 6-12-hour setting time and carefully mix up enough to fill the transducer housing. After mixing, allow it to stand for about 20 minutes to allow the air bubbles to escape, then pour it into the transducer housing.

Fill the housing right to the top so that the transducer element is completely immersed and keep an eye on it for an hour or so, topping it as it runs down behind the element. Use a pin to prick any air bubbles that emerge. Take care here, as any air bubbles can drastically degrade transducer performance.

On no account should you use polyester resin—you must use epoxy. Epiglass 40 resin is quite satisfactory.

Finally, fit the DIN plug to the end of the cable, and fit the red and black supply leads.

meters (VR2 and VR3 roughly midrange).

Now turn the alarm off and the display should go back to zero. Turn the sensitivity control fully clockwise and lightly tap the face of the transducer with a screwdriver handle. The display should flicker and momentarily read some random numbers. If the alarm is now set to maximum depth, it may be possible to trigger it by tapping the transducer face as above. (It will trigger only if you "hit" upon an echo reading of less than the alarm setting.)

Calibration

If all the above tests work, your depth sounder is functioning and will give readings if taken out in a boat. However, it has to be tuned and calibrated if we are to obtain maximum sensitivity and if the readings are to be accurate. If you have access to the appropriate test gear, this can be done easily on the bench; if you don't have test gear, the only way is to take the instrument out on the water.

Assuming that you don't have test gear, the procedure is as follows:

● *Tuning.* Advance the sensitivity control until an echo is obtained, then back it off until the echo is just lost. Now tune L1 carefully until the echo reappears (display reading). Reduce the sensitivity again and continue the process until the optimum setting is found for L1. L2 can be tuned in the same way, but as this has a low Q, its setting is not so critical. Most units will tune with the slug of L2 about flush with the top of the former.

● *Calibration.* Once the tuning is done, the calibration can be set if you have a chart. The problem is to find a known depth of water and set VR2 and VR3 to the known depth. Do not forget to allow for the fact that the transducer may not be at the surface if it is mounted on

the bottom of the boat; i.e., the instrument reads depth beneath the transducer.

It may even be possible to resort to the good old lead line to get an accurate depth measurement.

First, set switch S1 to the feet position and adjust trimpot VR2 until the display shows the correct depth. This done, set S1 to meters and adjust trimpot VR3. Note that VR2 must be set first as it affects the setting of VR3.

If you have access to an oscilloscope, a signal generator, and a frequency meter, the procedure is somewhat different:

● *Tuning.* Connect the oscilloscope probe to pin 1 of IC3 and couple in a 200-kHz signal to L2 via the .01- μ F capacitor. Now adjust L1 and L2 for maximum signal strength.

If no signal generator is available, then it is possible to get a signal echo in air. Clamp the transducer to the underside of the workbench and check that the unit is over a hard floor (carpet will not reflect ultrasound). Once an echo is being received, simply tune L1 and L2 for maximum signal strength. (Note: Because of the much lower velocity of sound in air than in water, the display will read about four and a half times the actual distance.)

● *Calibration.* A frequency meter connected to pin 5 of IC1b will allow precise setting of VR2 and VR3 to 2460 Hz and 750 Hz respectively. Alternately, you can use a CRO or a frequency meter to set the periods to 406 μ s and 1.333 ms respectively.

Once the unit is tuned and calibrated, it may be mounted in the case. To do this, lay the top half of the case (the half with the speaker in it) upside down on the bench and sit the circuit board on the four mounting pillars. Fit the front and back panels into the slots provided and fit the large brass nuts into the cav-

ities in the sides. Ensure that the board holes line up with the mounting pillar holes and fit the bottom half of the case.

The two halves will fit together closely and the four 12 mm \times no. 4 self-tapping screws may be fitted through the bottom holes and screwed into the mount-

ing pillars. The U-shaped mounting bracket may now be attached with the large plastic knob-headed screws. Fit the front-panel control knobs, and your instrument is ready for use.

Operation

The transducer is the key to satisfactory operation of

Parts List

- 1 printed circuit board, 111 \times 100 mm
- 1 printed circuit board, 41 \times 35 mm
- 1 SPST toggle switch
- 1 5-pin DIN socket and plug
- 1 plastic case, 125 \times 140 \times 58 mm
- 1 front panel to suit
- 1 8- Ω loudspeaker
- 2 knobs
- 1 U-shaped mounting bracket
- 2 mounting knobs for bracket
- 1 ultrasonic transducer kit
- 2 slug-tuned coils, L1 & L2

Semiconductors

- 2 LM3900, MC3401 quad op amps
- 1 LM1812 ultrasonic transceiver
- 1 MC14553 3-digit BCD counter
- 1 MC14511 BCD-to-7-segment decoder
- 3 2N5819 PNP transistors
- 1 2N5818 NPN transistor
- 11 1N4001 silicon diodes
- 3 MAN3640 7-segment LED displays

Capacitors

- 1 1000 μ F/16VW PC electrolytic
- 1 220 μ F/16VW PC electrolytic
- 2 47 μ F/16VW PC electrolytic
- 3 1 μ F/16VW tantalum
- 1 0.33 μ F mylar™
- 1 0.22 μ F mylar
- 2 0.1 μ F mylar
- 1 .018 μ F mylar
- 1 .01 μ F/250 V disc ceramic
- 3 .0047 μ F mylar
- 1 .0033 μ F/250 V disc ceramic
- 1 .0022 μ F mylar
- 4 .001 μ F mylar
- 2 100 pF disc ceramic

Potentiometers

- 1 100k linear potentiometer with DPST pull-on switch
- 1 10k mini-trimpot, horizontal mounting
- 1 5k mini-trimpot, horizontal mounting
- 1 5k linear potentiometer with SPST rotary switch

Resistors (1/4 W, 5% unless specified)

- 2 10 megohm
- 2 2.2 megohm
- 1 1.2 megohm
- 6 1 megohm
- 3 680k
- 1 470k
- 2 390k
- 1 330k
- 2 150k
- 4 100k
- 1 68k
- 1 47k
- 1 27k
- 2 12k
- 5 10k
- 2 3.3k
- 7 680 Ohms
- 1 22 Ohms
- 3 10 Ohms

Miscellaneous

Rainbow cable, tinned copper wire, solder, styrene adhesive, epoxy resin

any depth sounder, and a few tips on mounting may not go astray. Many people have mounted transducers inside the hull in a "water-box" and it is possible to get satisfactory results with this method. However, some sound attenuation will occur and this will reduce the range of the instrument. In the worst case, it may not work at all.

The best mounting method is on the outside of the hull, roughly in the middle third of the boat and as close to the center line as possible. It must be clear of any fittings and in an area of clear water flow. Turbulence and bubbles under the transducer will reduce its performance. In yachts, hull-heeling under sail will cause the transducer to fire its sound beam out at an angle and this will reduce sensitivity; if the boat heels far enough, the echo may be lost altogether. Mind you, when this happens, the crew

is usually too busy to be looking at echo sounders!

Installation of the unit should be straightforward, but keep the transducer and all leads as far away from the engine as possible to avoid ignition interference. If ignition interference does prove a problem (i.e., the display reading fluctuates randomly), choke L3 will have to be fitted in place of

the appropriate link on the PCB. This should be a power supply choke of around 10 mH in value.

Because this choke is not available from Monitor Instruments, it will have to be purchased separately, if required.

The maximum depth range attainable with this instrument will vary considerably and depends on a num-

ber of factors including tuning accuracy, transducer mounting, water turbulence, and bottom reflectivity. Bottom reflectivity will be high with a flat sandy bottom and may be nil with heavy weed growing over soft mud.

A typical unit should give a depth range of from 80-120 meters without any difficulty and possibly more with careful tuning and installation.

Note that apparently strange readings can occur with this type of instrument because the display is triggered by the first echo received. For example, echoes may be received from cold layers in the water, undersea currents, propeller wash from other boats, and even fish. The usual effect of this is a steady bottom reading of 30 meters, say, with occasional readings of much less, e.g., a fish at 20 meters or a salinity or cold water layer at 15 meters, etc. ■

KITS AND PARTS AVAILABLE

The sole supplier of the PCB, a proprietary design, is Monitor Instruments, PO Box 116, Rosebery, Sydney, 2018, NSW Australia. Any of the following ordered, when orders are received with payment, will be shipped within 5 days. Amounts are in US dollars.

- Fully assembled and tested Depth Sounder—\$180.00¹
- Complete kit (add \$12.00 for postage)—\$138.00
- Transducer kit (add \$7.00 for postage)—\$40.00
- Molded plastic case/mounting (add \$5.00)—\$25.00²
- Set of circuit boards (add \$5.00)—\$20.00
- Set of coils (add \$5.00)—\$12.50
- Set of semiconductors, complete (add \$5.00)—\$25.00³

¹Postpaid.

²Includes front and back panels, control knobs, and gimbal mounting bracket/knobs.

³Does not include the displays.

LINEAR

2 TO 400 MHZ

PLANBOOK

15 to
1000 WATT

14 Different Models, 100 pgs
\$11.95

A.P. Systems

Box 263 sm. ✓169

Newport, RI 02840 (401) 846-5627

PROGRAMMABLE CTCSS ENCODER/DECODER

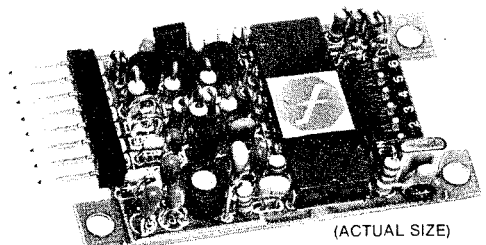

(ACTUAL SIZE)

- All 37 EIA Tones
- Quartz Accurate
- Universal

\$54.⁹⁵

**IMMEDIATE DELIVERY AVAILABLE
FROM NEW YORK AND CALIFORNIA
DISTRIBUTION CENTERS**

For more information call TOLL-FREE
(800) 828-6884
NY: (800) 462-7242
CANADA: (416) 884-3180 ✓218

FERRITRONICS
MOBILE DATA SYSTEMS

1319 PINE AVE.
NIAGARA FALLS NY 14301

AZDEN

PCS-4000

ADVANCED MICROCOMPUTER CONTROL - 16 MEMORIES - 25 WATTS - SUPER COMPACT 142-150 MHZ - ANY SPLITS - ONE-YEAR WARRANTY -

ALSO: PCS-300 HT, PCS-2800 10M FM, accessories, etc.

KDK

FM-2030

EASY TO OPERATE - SINGLE-KNOB TUNING - RIT - 10 MEMORIES - 25 WATTS - SCAN BAND OR MEMORIES - TT MIC. WITH UP/DOWN FREQ. CONT. - ANY SPLITS BEEPS AT MEMORY BAND LIMITS FOR EYES-OFF OPERATION

Special discounts - call for quote

B. G. CARL ELECTRONICS

11128 Claire Ave. ✓469 Northridge, CA 91326

Call: 1-213-363-1216 (anytime) Bryan AG6R