

# Balun Designs for Wireless, ...Mixers, Amplifiers and Antennas

*Baluns find wide use in mixer, antenna and balanced amplifier circuits, yet their design is not widely practiced. The author shows a variety of designs, that are simple and yield good first pass results.*

Rick Sturdivant  
Hughes Aircraft Company  
El Segundo, California

Baluns find wide use in mixer, antenna and balanced amplifier circuits. Yet balun design is still regarded as if it were black magic by many engineers, partly due to the fact that practical design information on baluns can be difficult to find. However, many good baluns have been developed over the years and some are surprisingly simple to design. In this paper we will review some good balun designs and show that good first pass design results can be obtained.

Balun circuits find wide application especially in new wireless applications as they have customarily in RF and microwave circuits. They are used in circuits such as mixers, push-pull amplifiers, antennas and other applications requiring a conversion between unbalanced transmission line (such as coax, stripline or microstrip) and a balanced line (such as a two wire transmission line of the type used for old television antenna leads).

A properly designed balun is essential for these types of circuits. In fact, it is often the performance of the balun which predominately determines the performance of the overall circuit.

Interestingly, the design of baluns is rarely covered in most engineering curriculum. Furthermore, the design information on them is scattered throughout a number of different articles. The goal of this paper is to save the circuit designer time by cataloging a few good balun designs.

### Balun Theory

The purpose of a balun is to form a good transition from an unbalanced transmission line into a balanced transmission line. Figure 1 illustrates coax, a familiar unbalanced line. The current  $I_1$  exists on the center conductor,  $I_2$  is the ground return for  $I_1$ , and  $I_e$  is the external current induced on the outside of the shield. The shield is considered tied to earth ground at the input.

A shielded parallel plate line, on the other hand, has equal potential and 180 degrees of phase difference between the current on the two conductors, with no current on the ground shield. This is illustrated in Figure 2. The currents are  $I_1 = -I_2$ , and  $I_3$  is the ground return.  $I_3$  exists only when the equal amplitude and opposite phase relationship between  $I_1$  and  $I_2$  is not maintained.  $I_e$  is the induced external current on the outside of the shield.

To speak of the potential at the balanced end of the circuit referenced to ground is unnecessary, since it is the potential between the balanced pair of conductors which is responsible for the transmission of power along them. In fact, for the theoretically perfect balun, an ideal current source placed between one of the balanced lines and ground will produce zero current in that line.

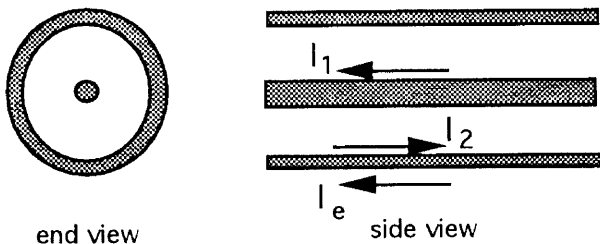

Figure 1. Coaxial line is an unbalanced transmission line.

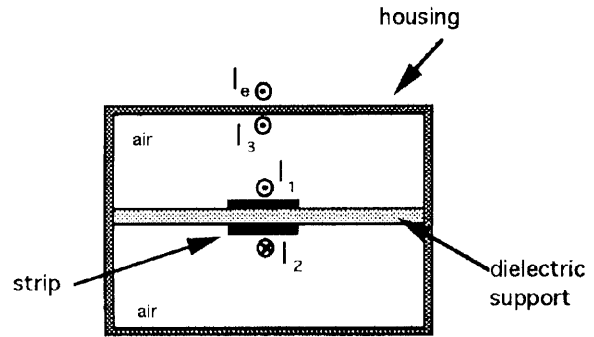

Figure 2. Shielded parallel plate line is a balanced transmission line.

However, for many mixer and amplifier designs it is not necessary to have a theoretically perfect balun. That is, many circuits do not require the infinite ground isolation property of the ideal balun. Rather, these circuits only require that the voltages on the balanced lines are of equal magnitude and opposite phase, and that the impedance to ground may be finite (but equal for both conductors). Baluns have been developed over the years which meet this requirement. These quasi baluns are the major focus of this article.

### Half Wave Transmission Line

Possibly the simplest balun is shown in Figure 3. The phase shift of 180 degrees which is required for balun operation is achieved by a half wavelength piece of transmission line. Impedance matching can be achieved by properly choosing the impedance of the halfwave line. This is an inherently narrow band design. A quarter wave transformer can be added at the unbalanced input to improve the performance. This circuit is designed by modifying the line impedance of the half wave and quarter wave line (if used) to achieve the best performance.

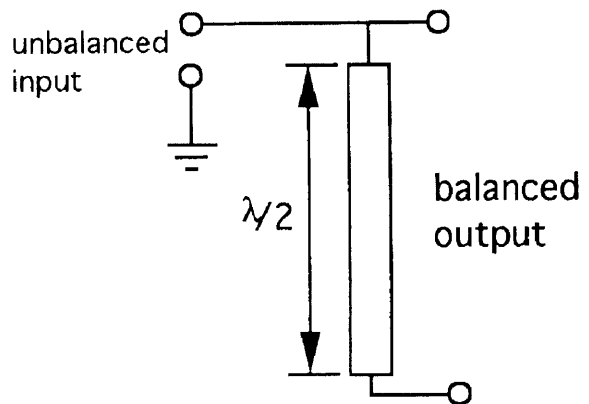

Figure 3. Simple half wavelength balun.

## N Sections of Half Wave Lines

By interconnecting a number of half wavelength transmission lines with quarter wavelength lines (Figure 4), wide band baluns are possible[1]. The bandwidth can be increased by adding more sections. The order, n, of the balun depends upon the number of halfwavelength sections. The half wavelength lines provide the 180 degrees of phase shift while the quarter wavelength lines give the impedance transformations. This is a balun design that is practical in microstrip. Due to its planar structure the circuit pattern can be etched on only one side of the substrate.

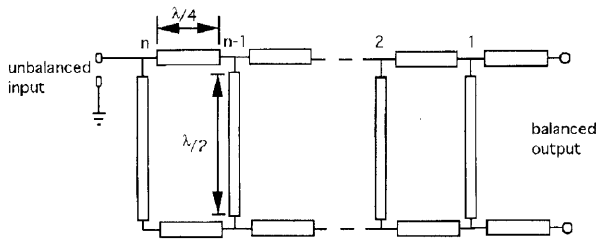

Figure 4. N section halfwave balun.

An n=2 form of this balun has been designed and tested. The element lengths and impedances have been optimized. The measured performance is shown in Figure 5.

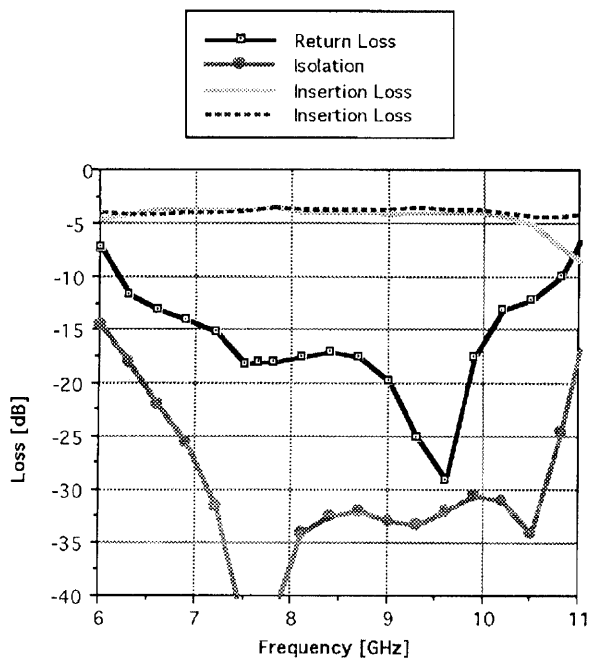
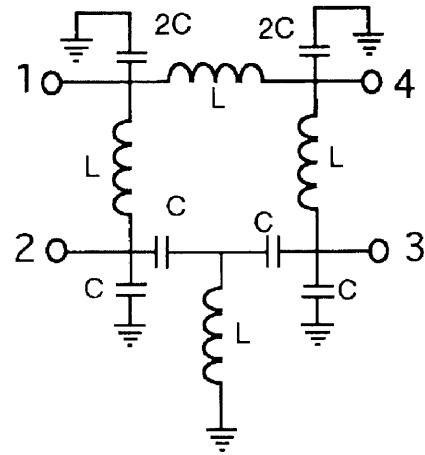

Figure 5. Measured performance of n=2 half wave balun.

## Lumped Element Balun

Baluns can be designed by using lumped elements. Lumped element baluns are well suited for low frequency and MMIC applications[2],[3] for which distributed line lengths would be too bulky. The theory of lumped element baluns is based upon the familiar rat race ring hybrid. The distributed transmission lines of the rat race ring are replaced by lumped element equivalent circuits. The quarter wave length lines of the rat race ring are replaced by lumped element lowpass filter networks. The three quarter wavelength line is replaced by a highpass filter network. The resultant equivalent lumped element circuit is shown in Figure 6. The required design equations are included.



$$\text{where: } \omega L = 1/(\omega C) = 1.41 4R$$

$$R = \text{Port Impedance}$$

$$\omega = \text{center frequency (rad/sec)}$$

Figure 6. Lumped element balun.

The theoretical performance of this balun is shown in Figure 7. A 50 ohm load was assumed on all ports. Therefore,  $C = 0.225\text{pF}$  and  $L = 1.125\text{pF}$ .

## Parallel Plate Balun

Of all the baluns in use today possibly the most widely used is the quarter wave coupled line balun. There are many configurations for it. The broadside coupled parallel plate balun is very common[4],[5],[6]. It is found in many mixer designs and is shown in Figure 8. It consists of an input microstrip line which transitions into parallel plate line. The parallel plate line is a double sided substrate.

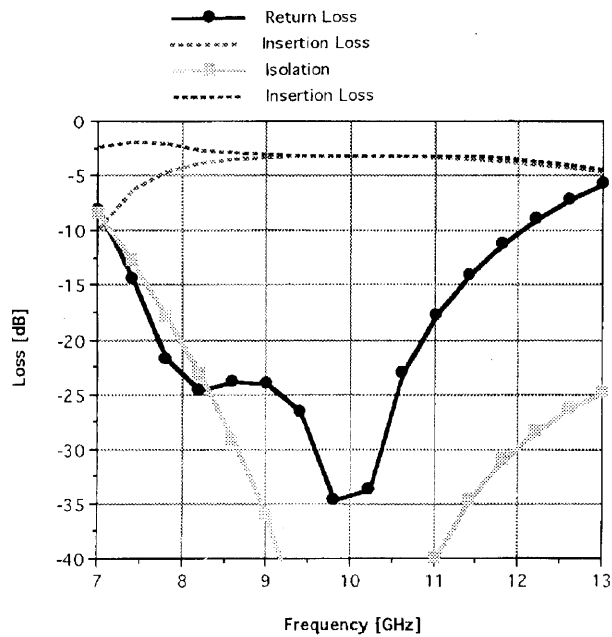

Figure 7. Theoretical performance of the lumped element balun.

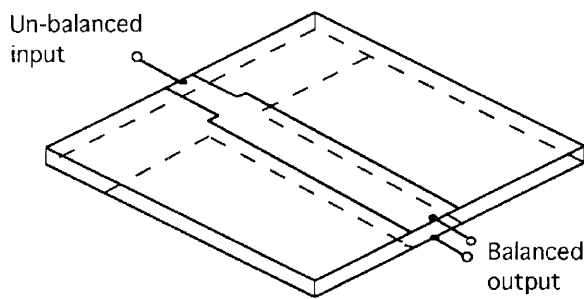

Figure 8. Parallel plate balun. Backside conductor shown as dashed lines, topside conductors as solid lines.

A taper is usually added to the backside ground plane to aid in the mode conversion from microstrip to parallel plate. However, relatively good performance is possible without using a taper if the even mode impedance is very large compared to the odd mode impedance. Usually soft substrates are used for the support dielectric and are usually very thin (5mil typically).

A side view of the balun is shown in Figure 9. The parallel plate region is actually a pair of coupled lines. The even and odd mode analysis can be done using the technique developed by Bhat and Koul[7] for the analysis of broadside coupled suspended substrate stripline (BCSSS). The odd impedance,  $Z_{oo}$ , is the characteristic impedance of one of the balanced conductors to ground when a shorting plane is placed at the symmetry line between the balanced conductors. The even mode impedance is the characteristic impedance measured between one of the balanced conductors and ground when

a magnetic wall is placed between the balanced lines. Their method, which is based on the variational technique, is straight forward and easy to program.

One of the benefits of the parallel plate balun is that it is possible to achieve ground isolation at the balanced outputs. That is the balanced lines have their potential referenced to each other, with near zero potential between either balanced line and ground.

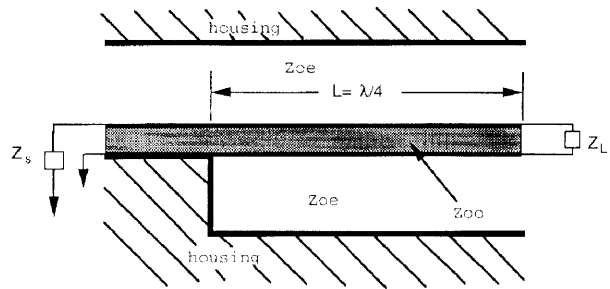

Figure 9. Side view of the parallel plate balun.

The actual parallel plate impedance ( $Z_{op}$ ) is twice the BCSSS odd mode impedance. Therefore, the impedance used for the design of the balun is related to the odd mode BCSSS impedance by

$$\text{Equation 1. } Z_{op} = 2Z_{oo}$$

Where  $Z_{op}$  is the parallel plate impedance. In order to have a good match at the microstrip input, we must have

$$\text{Equation 2. } Z_{op} = \sqrt{Z_s Z_L}$$

The parallel plate region of the balun is shown to be a quarter wavelength long. Use the effective dielectric constant for the odd mode BCSSS to determine this length. The even mode impedance must be very large compared to the odd mode impedance. As a minimum,

$$\text{Equation 3. } Z_{oe} \geq 10Z_{oo}$$

This design method was used and the theoretical response of the balun is shown in Figure 10. It used  $Z_{oo} = 35 \text{ ohm}$  and  $Z_{oe} = 350 \text{ ohm}$ . As can be seen, the power split is not the desired 3dB. However, as the even mode impedance increases relative to the odd mode impedance, the power split approaches the desired 3dB.

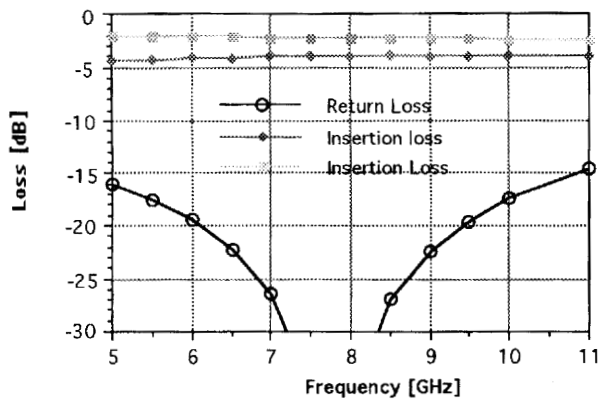

Figure 10. Frequency response of the parallel plate balun.

A parallel plate balun was used in the design of a mixer realized on 25 mil alumina ( $\epsilon_r=9.8$ ). The performance is good for a first cut design. The design called for a mixer with a bandwidth covering 8-10 GHz with less than 9dB conversion loss. The port VSWR was less than 2:1 using the balun configuration shown in Figure 8 with no taper to the trace on the back sides of the substrate. The conversion loss as a function of the r.f. frequency is shown in Figure 11.

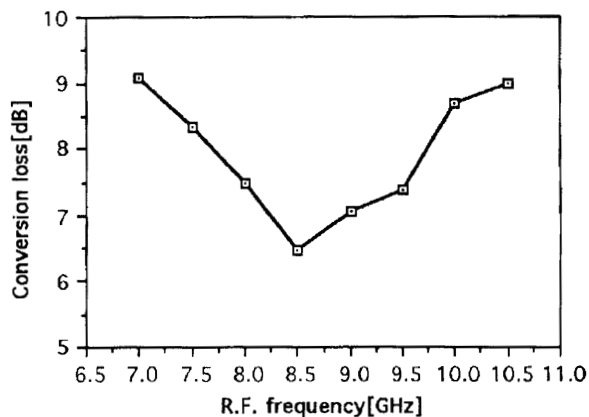

Figure 11. Conversion loss of the singly balanced mixer.

### Microstrip Coupled Line Balun

A design similar to the parallel plate balun can be made using coupled microstrip. The design procedure uses Equations 1-3. This type of balun has performance similar to that shown in Figure 10. However, the condition of Equation 3 can be difficult to satisfy in microstrip.

Using only two coupled lines does not usually give enough coupling to achieve good performance, better to employ three. A typical layout for this balun is shown

in Figure 12. The two lines which couple to the center strip are shorted at the unbalanced input and attached periodically by jumper wires. This short circuit causes the capacitance between these two strips and the ground plane to be shorted out. Transforming a quarter wave length to the balanced output causes the impedance to be very large (theoretically an open circuit).

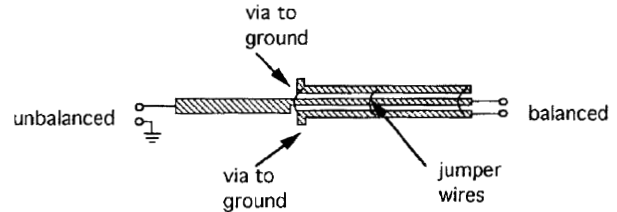

Figure 12. Microstrip balun using coupled lines where the coupled region is a quarter wave length long for the odd mode.

### Marchand Balun

A wide band balun which has been used for years is the Marchand balun[8]. Many examples of the Marchand balun can be found in the literature [8,9,10]. Figure 13 is an example of a coaxial line Marchand balun.

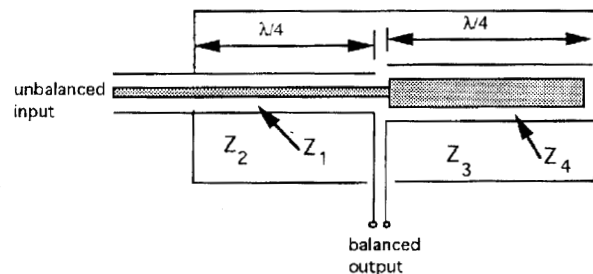

Figure 13. Marchand balun in coax.

Published analyses suggest that bandwidths approaching 50:1 theoretically are possible. The author is aware of realizations yielding bandwidths of 8:1. The design is amenable to both coax and microstrip media.

A quasi Marchand balun is shown in Figure 14. This is not a true Marchand balun due to the fact that the even mode impedance between the coupled lines is defined between each line and ground. With this embodiment there is a finite (even mode impedance) between the non-grounded lines and ground. This is an additional impedance not represented in Marchand's balun. The predicted performance is shown in Figure 15. For  $Z_{00} = 35$  ohm and  $Z_{0e} = 250$  ohm and 50 ohm loads on the ports.

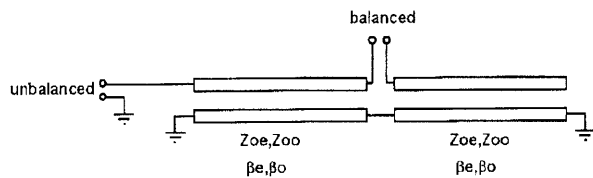

Figure 14. Quasi Marchand balun using coupled lines.

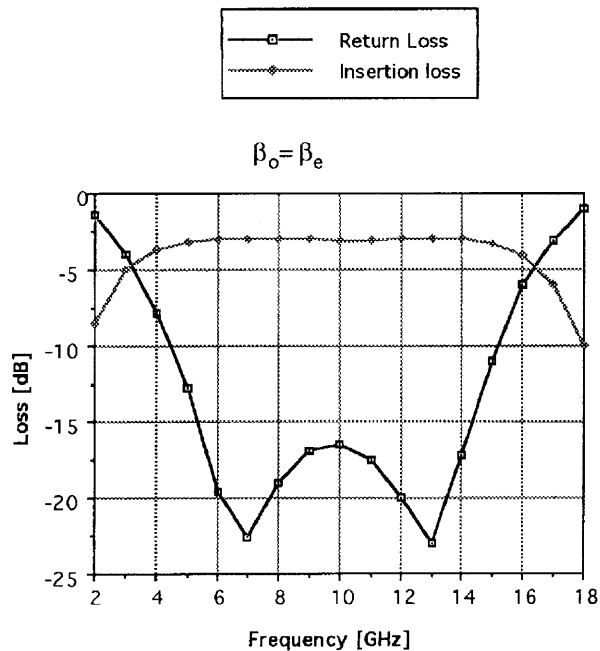

Figure 15. Calculated response of the quasi-Marchand balun.

### References

[1] B Mayer, R Knoechel, "Biasable balanced mixers and frequency doublers using a new planar balun," Conference Proceeding: 20th European Microwave Conference, V2, 1990, pp. 1027-1032.

[2] Samuel J. Parisi, "Monolithic, lumped element, single sideband modulator," 1992 IEEE MTT-S International Microwave Symposium Digest, pp. 1047-1050.

[3] S. J. Parisi, "180 degree lumped element Hybrid," 1989 IEEE MTT-S International Microwave Symposium Digest, Vol. 3, pp. 1243-1246.

[4] C. Y. Ho, "New analysis technique builds better baluns", *Microwaves and RF*, Aug., 1985, pp. 99-102.

[5] B. Climer, "Analysis of suspended microstrip taper baluns," *Proc. IEE*, Vol. 135, Pt H, No. 2 April 1988, pp. 65-69.

[6] S. Padin, B. Arend, G. Narayanan, "A wideband SSB mixer using high frequency operational amplifiers," *Microwave Journal*, March 1992, pp. 131-133.

[7] B. Bhat and S.K. Koul, "Unified approach to solve a class of strip and microstrip-like transmission lines," *IEEE Trans. Microwave Theory Tech.*, vol. MTT-30, pp. 679-686, May 1982.

[8] N. Marchand, "Transmission line conversion transformers," *Electronics*, 1944, 17, pp. 142-145.

[9] J.W. McLaughlin, R.W. Grow, "A wide-band balun," *IRE Trans.*, 1958, MTT, pp. 314-316.

[10] R. Bawer, J.J. Wolfe, "A printed circuit balun for use with spiral antennas," *IRE trans.*, 1950, MTT, pp. 319-325.

Rick Sturdivant received the BA Degree in Religion in 1986 from Southern California College and the BSEE Degree from California State University at Long Beach in 1989. In 1992 he received the MSEE Degree from the University of California at Los Angeles.

In 1989 he joined the Radar Systems Group at Hughes Aircraft as a Member of the Technical Staff. Presently he is responsible for the design of high density microwave packages for application to radar systems. While at Hughes he has been responsible for IR&D projects on miniature circulators and diplexers and the design of MICs for EW and radar systems. His interests are in microwave packaging, and the design of filters, mixers, and circulators.

Rick is a member of Tau Beta Pi, and Eta Kappa Nu.

